

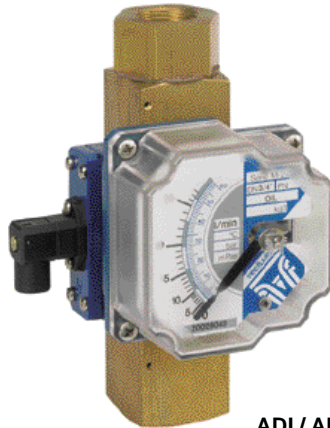

AD-15



ADI / ADT-15

### Working principle

#### Series AD-15, ADI-15, ADT-15

If a fluid flows with enough flow rate through a metering pipe A, with a mobile disc B and a calibrated spring C, the disc will be displaced.

The distance depends on:

- The flow rate F.
- The relation between the areas A and B.
- The opposing force of the calibrated spring C.
- The equilibrium of the forces defines the position of the calibrated disc B, and at the same time, the flow rate.

The calibrated disc B has a magnet M. The magnetic field acts on the alarms, the indicator or the transmitter.

- A = Metering tube
- B = Calibrated metering disc
- C = Calibrated spring
- F = Flow rate
- M = Magnet

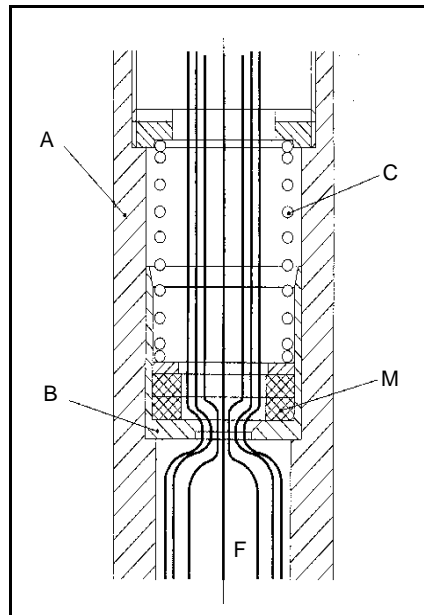

## Technical data

### Series AD-15, ADI-15, ADT-15

- Accuracy:  $\pm 5\%$  of full scale.
- Measuring range: 10:1,6
- Disc displacement: 40mm  $\pm$  5mm.
- Scales: In l/h, l/min, l/seg, m<sup>3</sup>/h, %, etc.
- Mounting positions: Vertical or horizontal. Flow rate in any direction.
- Connections: From 1/4" BSP to 2 1/2" BSP. Others on demand.
- Materials: Brass from 1/4" to 1". Aluminium from 1 1/4" to 2 1/2". (AISI-316, PTFE on demand)
- Maximum pressure: 16 bar.
- Maximum temperature: 100°C continuous, 120°C maximum.
- Alarms: - 1/4" and 1/2" connections:  
ADR-01: Reed 0,25A 125V 3VA  
- 3/4" to 2 1/2" connections:  
ADR-11: Reed 0,5A 250V 60VA  
Polyamide housing with IP65 connector.  
/1A = 1 alarm.  
/2A = 2 alarms.
- Indicator: Needle on a graduated scale. Flow rate units. Aluminium housing with plastic window.
- Transmitter: 4-20 mA. 2-wires, linear scale, series Halltec II. HALL sensor without contact with the metering system.
- Power supply: 15 to 50 Vdc.
- Temperature: -5 to +70°C.
- Precision: Analog output respect the magnet position: < 0.6%
- Maximum load in the 4-20 mA loop:  
(Vs—10)/0.02 O  
(Vs is the supply voltage).
- Consumption: Maximum 20 mA.
- Complies with 73 / 23 / CEE directive

Flow Table:

Size	Standard Flow in LPM		Recommended Flow (at 50% of full scale range) in LPM
	Min.	Max.	
1/4"	0.25	1	0.2
1/4"	0.5	2.5	1.5
1/2"	1	5	3
1/2"	1.5	10	5
1/2"	2	17	10
3/4"	5	30	15
3/4"	6	40	20
1"	10	50	25
1 1/4"	15	70	35
1 1/2"	40	160	80
2"	70	220	110
2 1/2"	100	270	135

## Adjusting the set point

The switch housing has a line on the side next to the graduated scale.

The position of this line indicates the value at which the switch will act.

The switch is held in position by means of a screw in a guide.

To adjust the position of the switch, loosen the fixing screw and slide the switch to the desired position.

## Connection

In the female connector (A):

Terminal 1: Reed common.

Terminal 2: Normally closed.

Terminal 3: Normally open.

Earth terminal: No connection.  
( Reed on zero position ).

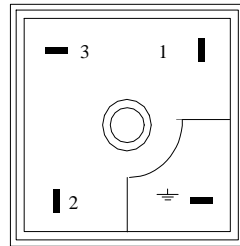

## Installation

Once the electrical connection has been made and the cable gland is tight, assemble in the correct position the female connector (A) on the male base (C). Don't forget to put the rubber seal (B) between the connectors.

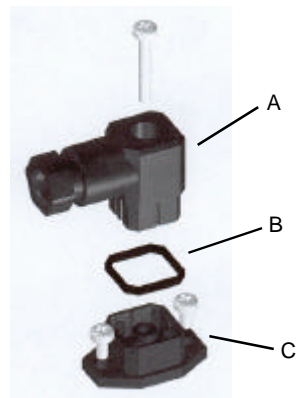

Install the flow rate detector in a pipe, with the arrow in the fluid direction.

For the electrical installation, a multi-conductor cable should be used to obtain a good seal with the cable gland. The connector is provided with a PG 9 cable gland, suitable for a 4.5 to 7 mm outside diameter cable. Connect the reed switch as required. Terminal 3 of the connector is the common, terminal 2 is the normally closed (N.C.) contact and terminal 1 is the normally open (N.O.) contact when there is no flow. The fourth terminal is an earth connection which is connected to the body of the flow rate detector.

The electrical installation should provide a fuse or circuit breaker to protect the reed switch from overloads.

Make sure that the contact rating is not exceeded. If high loads are to be switched, use an auxiliary relay.

When using inductive loads, such as relays or electro-valve coils, surge arresters should be installed to protect the reed contacts.

With a dc supply, a diode should be connected as shown.

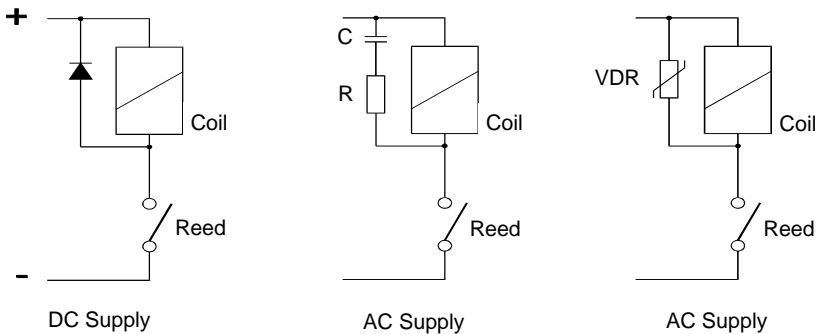

For an ac supply, an RC circuit can be used as shown, although a varistor (VDR) is better and is easier to select the right value. The VDR should have a breakdown voltage greater than 1.5 times the rms voltage. The standard varistor ratings specify the rms working voltage for the varistor, for example a S05K25 varistor will be for 25  $V_{rms}$  working and will have a breakdown voltage of 39 V at 1 mA.

## Mounting

### Rising

Series AD-15/BD  
ADI-15/BD  
ADT-15/BD

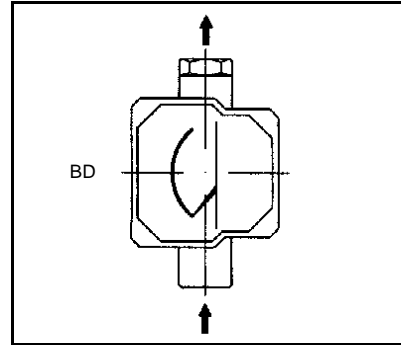

### Falling

Series AD-15/DAB  
ADI-15/DAB  
ADT-15/DAB

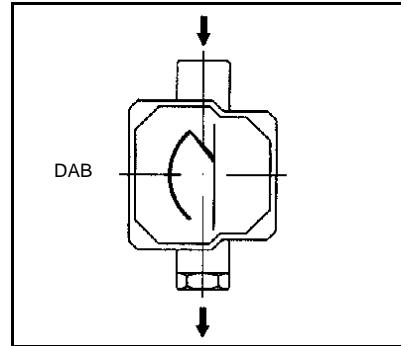

### Right to Left

Series AD-15/DES  
ADI-15/DES  
ADT-15/DES

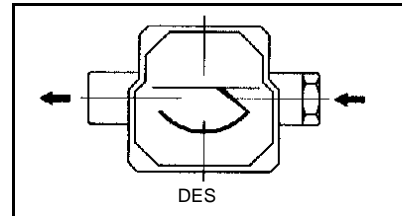

### Left to Right

Series AD-15/ED  
ADI-15/ED  
ADT-15/ED

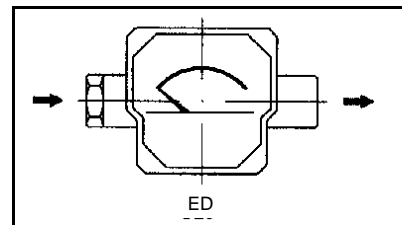

### Marketed by:

Malema Sensors  
1060 S.Rogers Circle  
Boca Raton, FL 33487  
U.S.A  
Tel: 1-561-995-0595, Fax: 1-561-995-0595  
email: IndustrialSales@malema.com  
URL: www.malema.com

