

# spirax/sarco®

## S-FP-93 Flow Processor

### Description

The Spirax Sarco S-FP-93 is a microprocessor-based instrument that is designed to monitor a variety of flows within industrial environments. The single-board design enables high reliability in a low cost form factor. Pressure and/or temperature compensation and an 8-point flow calibration curve may be used to further enhance performance. Diagnostic routines constantly monitor the S-FP-93's performance, automatically displaying any detection of a fault. The S-FP-93 features a backlit display that is readable in all lighting conditions. An industrial rated NEMA 4 enclosure is available for protection against harsh environments.



### Features

- Displayed values with description and user-selectable, engineering units
- Non-volatile memory for programmed data
- Battery-backed memory for statistical values and totalizers
- Self-diagnostics and operational alarm monitoring
- 16-bit resolution A/D converter for superb analog accuracy
- Isolated outputs for digital and analog control
- Backlit display option for viewing in all lighting conditions
- Light weight and low power consumption
- EIA RS-232C compatible communications interface
- Panel mount unit or optional NEMA 4 enclosure

### Benefits

- Calculates volume, mass, and heat flow for steam, liquid, and gas
- Single-board design for low cost and high reliability

### Dimensions and Weights

Dimensions are in inches

#### Panel Mount Enclosure

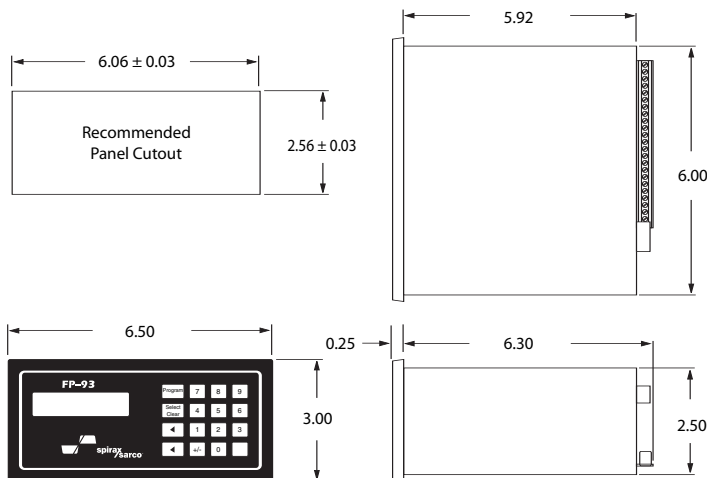

Weight 1.25 lb

#### NEMA 4 Enclosure

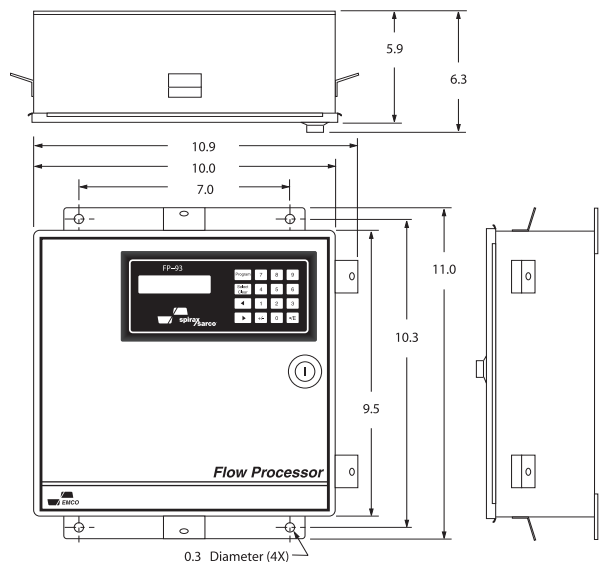

Weight 15.0 lb

*Local regulations may restrict the use of this product below the conditions quoted. Limiting conditions refer to standard connections only. In the interests of development and improvement of the product, we reserve the right to change the specification.*

TI-8-604-US 10.05

# S-FP-93 Flow Processor

## Operating Specifications

<b>Fluid Types</b>	Steam condensate, water, water energy, liquid, air, natural gas, ideal gas, steam	
<b>Storage Temperature</b>	-40 to 140°F	
<b>Operating Temperature</b>	32 to 122°F	
<b>Relative Humidity</b>	0 to 95% (non-condensing)	
<b>Power Requirement</b>	The FP-93 power supply, 24 VDC $\pm$ 5% at 150 mA, is used for powering external transmitters.	
Standard	10.5 to 36 VDC, 100 mA maximum	
Option 1	115 VAC $\pm$ 15% @ 50/60 Hz	
Option 2	230 VAC $\pm$ 15% @ 50/60 Hz	
	2 x 3 x 1.75" with 6' cords	
	VAC Power Weight—1.25 lb	
<b>Input Signals</b>		
One Frequency	Range 0 to 10 kHz	
	Accuracy $\pm$ (0.01% of reading + 1 count)	
	Impedance 50 k $\Omega$ minimum	
	Transition Level +3 volts nominal	
	Hysteresis 0.25 volts	
	Signal Amplitude 4 to 36 VDC	
One Direction	Impedance 50 k $\Omega$ minimum	
	Transition Level +3 volts nominal	
	Hysteresis 0.25 volts	
	Signal Amplitude $\pm$ 36 volts maximum	
	One 4-Wire RTD Resistance	Range 10 to 4000 $\Omega$
		Resolution—the greater of 0.05% of reading or 0.1 $\Omega$
	Accuracy	10 to 100 $\Omega$ $\pm$ 0.15 $\Omega$
		100 to 2000 $\Omega$ $\pm$ 0.15% of reading
		100 to 4000 $\Omega$ $\pm$ 0.2% of reading (extended range)
Two Analog (4 to 20 mA) Current	Resolution 0.4 $\mu$ A	
	Accuracy $\pm$ 0.15% of full scale ( $\pm$ 30 $\mu$ A)	
	Impedance 100 $\Omega$	
	Alarm Limits	Overrange 21.6 mA
		Underrange 2.4 mA
<b>Output Signals</b>		
One Isolated 4 to 20 mA Current	Voltage Range 15 to 40 VDC	
	Resolution 6 $\mu$ A	
	Accuracy $\pm$ 0.25% of full scale ( $\pm$ 50 $\mu$ A)	
One Isolated Solid-State Relay	A maximum up to 60 VDC	
<b>Communications</b>		
Compatibility	EIA RS-232C	
Multi-Drop Capability	Up to 10 units on a single RS-232C port (RS423 compatible)	
Programmable Baud Rate	300, 600, 1200, 2400, 4800, 9600, 19200, or 38400 baud	
Data Bits	7 or 8	
Parity	Even, odd, or none	
Stop Bits	1 or 2	
Connector	Chassis mounted 9-pin D-subminiature	

The analog input can be configured for flow input in all applications except BTU measurements with two RTD temperature inputs. For BTU measurements, select frequency input for flow.

# S-FP-93 Flow Processor

## S-FP-93 Programmed Constants

Column #1	Column #2	Column #3	Column #4 Fluid Parameters	Column #5 Totalizer	Column #6 Analog Output	Column #7 Relay Output	Column #8 Displayed Values	Column #9 Display Units	Column #10 System
Fluid	Flow	Temp input	Density from	Total #1	Analog out-	Relay output	Bar graph	Velocity units	Unit number
Steam/cond	Frequency	None	Temp. input #1	None	put	None	Off/On	ft/sec	Baud rate
Water	4 to 20 mA	RTD	Temp. input #2	Volume flow	None	Temp alarm	Density	cm/sec	38400
Water energy	Substitute	4 to 20 mA	Ref. density	Comp flow	Temperature	Temp #2 alarm	Off/On	m/sec	19200
Liquid	Flowmeter	Substitute	Specific gravity	Mass flow	Temp #2	Diff Temp alarm	Temperature	Volume units	9600
Air	Linear	Sub temp #1	Mole frac CO <sub>2</sub>	Energy flow	Diff Temp	Pressure alarm	Off/On	cubic feet	4800
Natural gas	Non-linear	RTD #1 cal A	Mole frac N <sub>2</sub>	Scale factor	Pressure	Density alarm	Temp Stats	cubic inches	2400
Ideal gas	Insertion	RTD #1 cal B	Supercomp	Total #1	Density	Velocity alarm	Off/On	gallons	1200
Steam	Small turbine	RTD #1 cal R	Viscosity	None	Velocity	Vol flow alarm	Pressure	barrels	600
	Large turbine	Zero scale	Temperature #1	Volume flow	Volume flow	Comp flow alarm	Off/On	cubic cm	300
	Interpolation	Full scale	Density #1	Comp flow	Comp flow	Mass flow alarm	Pressure stats	liters	Data format
	Linear	Temp Input #2	thru	Mass flow	Mass flow	Energy alarm	Off/On	cubic meters	7 Even
	Cubic Spline	None	Temperature #8	Energy flow	Energy flow	Total #1	Line velocity	quarts	7 Odd
	Bidirectional	RTD	Density #8	Scale factor #2	Zero scale	Total #2	Off/On	Mass units	8 None
	On/Off	4 to 20 mA			Full scale	Alarm limit	Volume flow	pounds	Stop bits
	Substitute freq	Substitute				Low	Off/On	tons	1/2
	Pipe diameter	Sub temp #2				High	Vol flow stats	grams	Comm hand-
	Obscuration	RTD #2 cal A				Setpoint	Off/On	kilograms	shake
	Profile factor	RTD #2 cal B				Hysteresis	Comp vol flow	metric tons	None
	K-factor	RTD #2 cal R					Off/On	Energy units	Hardware
	Full scale vel	Zero scale					Comp vol stats	Btu	(CTS)
	Full scale freq	Full scale					Off/On	kJ	XON/XOFF
	Diff press cal	Pressure input					Mass flow	cal	Both
	Frequency #1	None					Off/On	kcal	Modem
	Velocity #1	4 to 20 mA					Mass flow stats	Mcal	Comm
	thru	Substitute					Off/On	ton	Off/On
	Frequency #8	Sub pressure					Energy flow	kW	Password
	Velocity #8	Zero scale					Off/On	MW	Display scan
		Full scale					Energy stats	GW	Sync calc
		Atm pressure					Off/On	Flow time	Off/On
							Analog output	base	Temperature
							Off/On	/second	TC
							Relay output	/minute	Pressure TC
							Off/On	/hour	Flow TC
							Total #1	/day	A/D reference
							Off/On	Temp units	A/D int count
							Total #2	°F/°R/°C/K	D/A zero
							Off/On	Pressure units	count
							Clock/Calendar	psi	D/A span
							Off/On	atm	count
							Verification	bar	
							Off/On	kg/cm <sup>2</sup>	
								mm Hg	
								Pressure dis-	
								play	
								absolute	
								gauge	
								Density units	
								lb/ft <sup>3</sup>	
								g/cc	
								kg/m <sup>3</sup>	

# S-FP-93 Flow Processor

## Model and Suffix Codes

Category	Suffix Codes					
<b>Model</b> Microprocessor-Based Flow Processor	S-FP-93					
<b>Enclosure</b> Panel Mount Unit NEMA 4 Rated Enclosure		P N				
<b>Power Supply</b> 10.5 to 36 VDC 115 VAC, 50/60 Hz <sup>1</sup> 2305 VAC, 50/60 Hz <sup>1</sup>			0 1 2			
<b>Relay Output</b> DC Option				D		
<b>Display</b> Standard Display Display with Backlighting					S B	
<b>Flow Input</b> Frequency Analog 4 to 20 mA						F A
<b>Example</b>	<p style="text-align: center;"><b>S-FP-93- P- 0- D- S- F</b></p> <p style="text-align: center;">S-FP-93-P-0-D-S-F represents a panel mount unit, 10.5 to 36 VDC power supply, DC option relay output, standard display, with frequency flow input.</p>					